

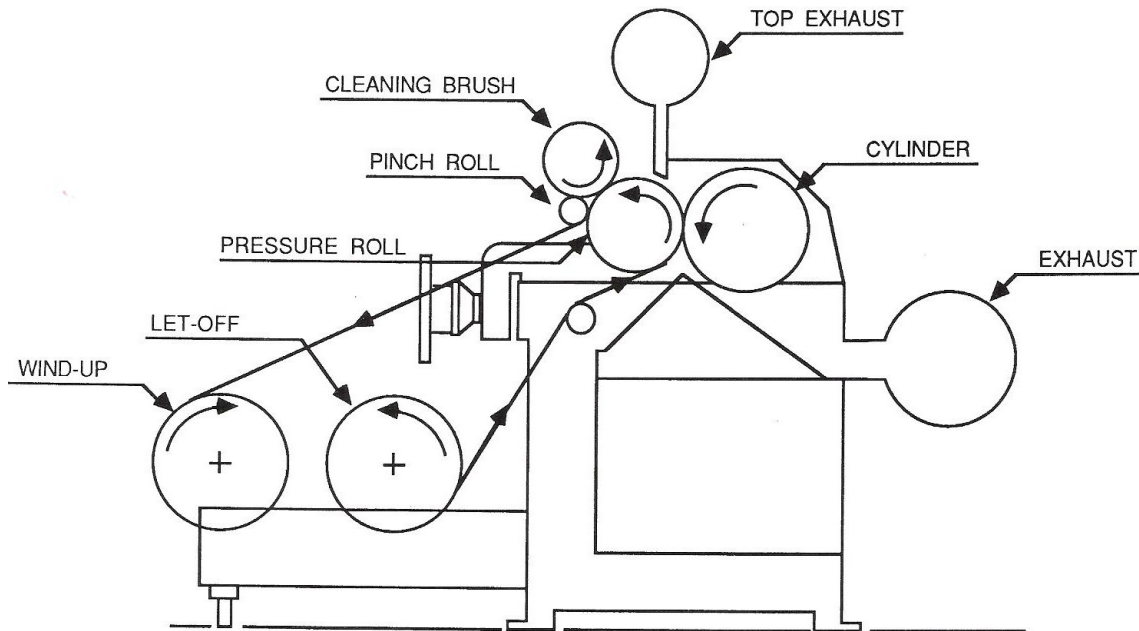

The position of the pressure roll in respect to the cylinder is controlled by micrometer had-wheels graduated in .001". The adjustment is so accurate that print can be sanded from ordinary newspaper without harming the paper itself.

The heart of the machine is a dynamically balanced cylinder to which industrial coated abrasive is applied. The cylinder is drilled for water circulation to help diffuse friction heat, preventing distortion of the .0005" concentricity.

Below is an illustration of material flow as it passes over the rubber pressure roll to come into contact with the machine's cylinder. From the cylinder, it continues on to a material cleaning brush and then exits from the machine.



Demonstration equipment available at our Gloversville Plant. Send or bring us your samples or finishing problems.