

PRODUCTIVE ACCURACY

771 SERIES

TOP & BOTTOM RIGID MATERIAL GRINDER
24" MACHINE SHOWN
(Custom Sizes Available)



Uses: grind to size corrugated cardboard for hollow core doors.

CURTIN-HEBERT MACHINES

11 Forest Street P.O. Box 511
Gloversville, New York 12078-0511
PH 518-725-7157 FAX 518-773-3805

EMAIL: sales@curtinhebert.com

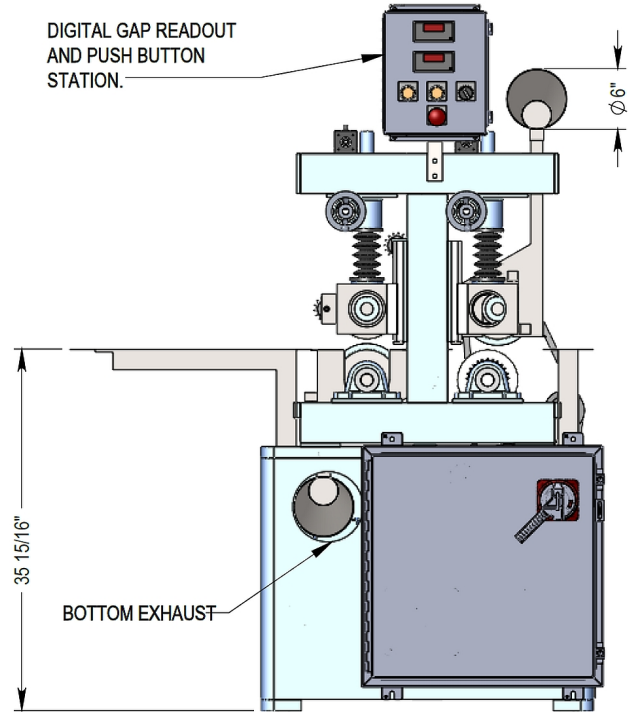
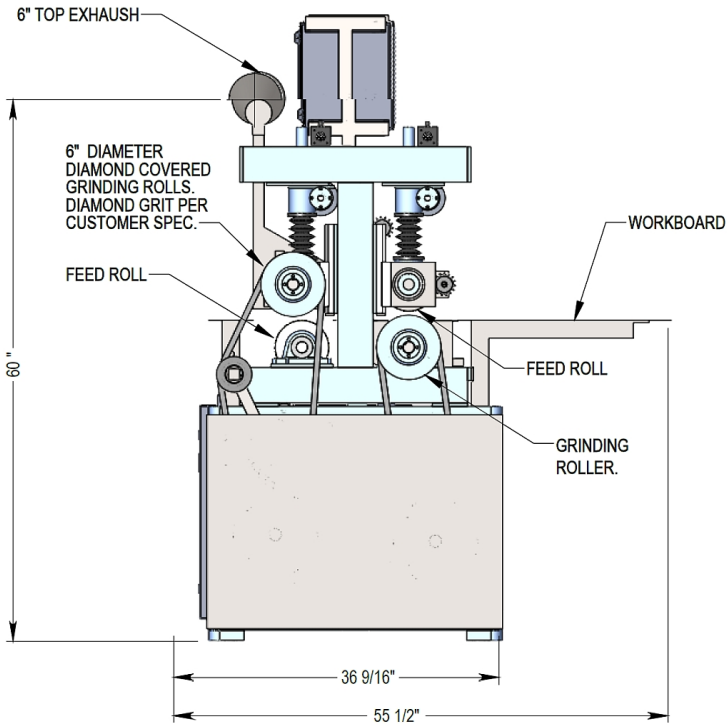

Demonstration equipment available at our Gloversville Plant.
Send or bring us your samples or refinishing problems